

AUTOGLIDE

smart entry system

User Instruction manual for Cardale Autoglide

NOTE TO INSTALLER: This user manual is supplied for the instruction of the end user. It contains important safety and warranty information. This manual **MUST** be left with the end user on completion of the installation and after carrying out setting and safety checks.

Thank you for buying a Cardale Autoglide electric operator. This product will give many years of useful service provided it is used correctly and is properly maintained.

IMPORTANT SAFETY INSTRUCTIONS

WARNING – IT IS VITAL FOR THE SAFETY OF PERSONS TO FOLLOW ALL INSTRUCTIONS PLEASE KEEP THESE INSTRUCTIONS



The opener should be activated only when the door is in full view, free of obstacles and correctly adjusted. Nobody should enter or leave the garage while the door is moving. Children should NOT be allowed to play near the door.

Never let children operate, or play with the door controls. Keep remote control away from children

SAFETY NOTE: If there is a chance that children may play in the entry of the garage then ensure the child lock is **ENABLED** so that the door **CANNOT** be operated from the  button (see **Section 6c**)



Always keep a moving door in sight and away from people and objects until it is completely closed.

NO ONE SHOULD CROSS THE PATH OF A MOVING DOOR.



The safety reverse system test is very important. Your garage door must reverse when obstructed on closing. Failure to properly adjust the operator may result in serious personal injury from a closing garage door. Repeat the test once a month and make any needed adjustments (see **Section 5** in this manual – Safety Sensitivity check.)

CARDALE[®]
GARAGE DOORS
Strong • Stylish • Secure



AUTOGLIDE

smart entry system



Do not use the force adjustments to compensate for a binding or sticking garage door. Excessive force will interfere with the proper operation of the safety reverse system or damage the garage door.



Keep garage door balanced. Sticking or binding doors must be repaired. Garage doors, door springs, cables, pulleys, brackets, and their hardware are under extreme tension and can cause serious personal injury. **Do not attempt adjustment.** Call for professional garage door service.

Installation and wiring must be in compliance with your local building and electrical codes. Connect the power cord only to properly earthed mains. Use the ring main 13 amp 3 pin socket installed by a qualified electrician. The plug should be fitted with a 5 amp fuse.

THIS APPLIANCE MUST BE EARTHED.

NOTE: For optimum electrical safety this operator should be connected to a circuit protected by an R.C.D (Max 30mA trip rating).



If the garage has no service entrance door then an exterior release kit **MUST** be fitted. This accessory allows manual operation of the garage door from outside in case of power failure (See page 19).

Disconnect electric power to the garage door operator before making repairs or removing cover.



Use the manual release lever to disengage the motor drive **ONLY** when the drive is switched **OFF** and, if possible, when the door is fully closed.



Frequently examine the installation, in particular the cables, spring and mountings, for signs of wear, damage or imbalance. Do not use if repair or adjustment is needed since a fault in the installation or an incorrectly balanced door may cause injury. Call for professional garage door service.



IMPORTANT SAFETY NOTE

Only operate the door when the door is in full view, free of obstacles with no persons (particularly children) near the door. Nobody should be allowed to enter or leave the garage whilst the door is in motion.

1 How to operate your Autoglide door opener

Stand by mode

When the Autoglide unit is switched on and in STAND BY MODE awaiting a command the following indicator LED will be seen on the control cover.

-  LED – Constant red indicating “power on”.
-  LED – will be flashing green or constant green dependant on CHILD LOCK setting (see **Section 6c**).

- IN LEARN MODE**
See relevant section for description.
- IN STANDBY MODE (awaiting command)**
Continuous **GREEN** – child lock enabled
Flash **GREEN** – child lock disabled
- IN RUN MODE**
Continuous **GREEN** – motor running, door in motion
Flash **RED** – obstruction or other problem

Continuous **RED** power on to unit.

ORANGE when remote control signal is received.

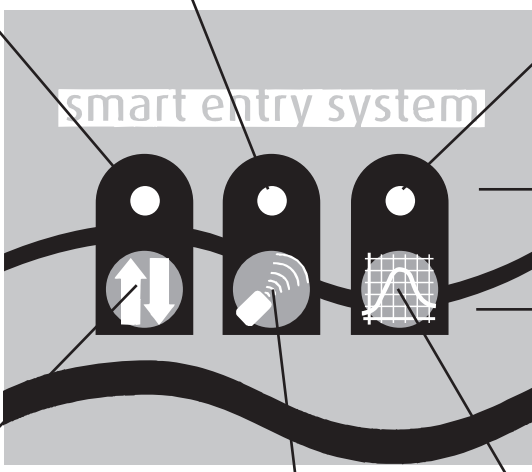

up/down – Press this button to open/close the door (depending on child lock config). In set-up mode this button selects the enable /disable of the child lock.

handset – Configures the remote control handset(s).

config – Configures the power /sensitivity settings of the motor and configures the child lock.

● Figure A



AUTOGLIDE

smart entry system

2 To open/close from outside the garage.

- Use the remote control handset.
- Press the selected button for approximately 1 second.
- A red LED on the hand transmitter indicates that the signal is being sent.
- An orange LED will light above the  button to indicate signal has been received.

3 To open/close from inside the garage.

- Use the handset as in **item 2**.
- Alternatively use the  button on the front of the unit, provided the child lock is disabled (flashing green  LED (see **Section 6c**)).
- Or, use the remote bell push button.

NOTE: Whenever the unit is operated the courtesy lamp is illuminated. This stays on for approximately 3 minutes and goes off automatically.

IMPORTANT SAFETY NOTE

Only operate the door when the door is in full view, free of obstacles with no persons (particularly children) near the door. Nobody should be allowed to enter or leave the garage whilst the door is in motion.

4 If the handset or stop button is operated whilst the door is still in motion.

- The door will stop and remain in that position until the next command signal is received.
- The next operation of the handset or button will reverse the direction of travel of the door.

5 If the door is obstructed whilst closing.

- The safety sensitivity circuit will activate and stop the door. The door will then reverse to the fully open position.

6 If the door is obstructed whilst opening.

- The safety sensitivity circuit will activate and stop the door.
- The door will stay in this position until it receives another command signal, it will then go to fully closed position.

NOTE: Because the Autoglide utilises the existing latching arrangement on your door you **MUST** keep the door locked at all times.

2 How to use the manual release

- 1 The manual release lever disengages the motor drive from the door, and allows the door to be opened and closed manually.
- 2 It can be used in an emergency (power cuts etc) or when carrying out checks and adjustments to door operation in manual mode.
- 3 **CAUTION!** Only use the manual release lever when the **POWER** to the unit has been turned **OFF** and for safety only disengage lever when door is closed, if possible.
- 4 The manual release lever is situated on the drive unit (see **Figure B**) and is coloured red.
- 5 To disengage the power drive, push the lever in the direction indicated in **Figure B**.



To re-engage the drive pin:

- 1 Ensure power switch on the unit is in the **OFF** position.
- 2 Identify drive pin hole in Dymetrol tape in drive track (hole is marked with silver paint). See **Figure C**.

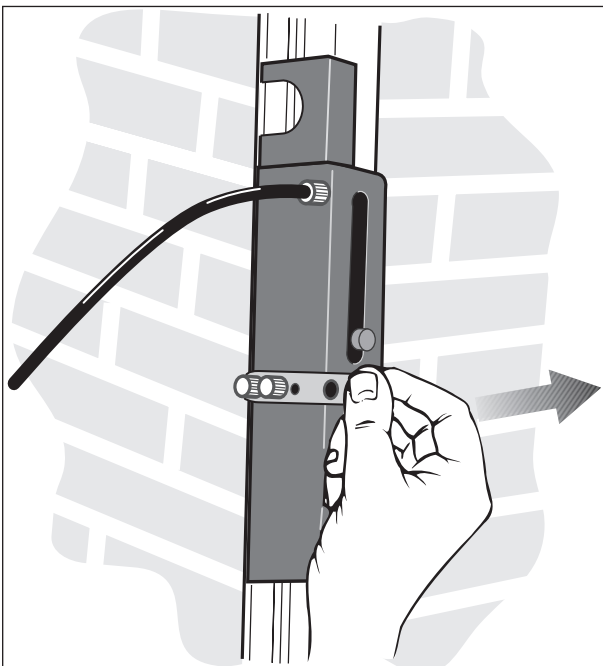

● Figure B

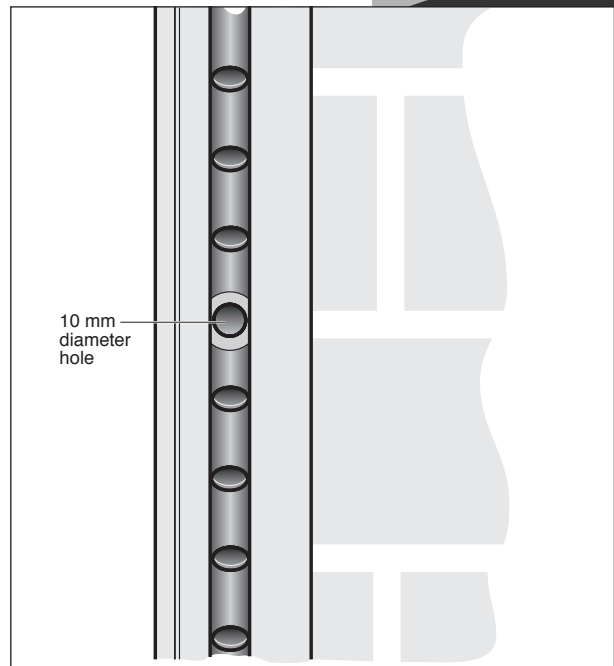

● Figure C

AUTOGLIDE

smart entry system

- 3** Position the garage door so that the red manual release lever aligns with the 10mm diameter hole.
- 4** Pull the manual release lever back so that drive pin fully engages into the hole (see **Figure D**).
- 5** Check pin is correctly engaged by trying to manually open/close door, the door should not be able to move. If it does then repeat steps 2–4.
- 6** Switch power on and test operation of door.

NOTE: In the event of power failure the **MANUAL RELEASE LEVER** can be used to restore door to normal manual operation.

When using the door in manual mode you should lock/unlock the door with the key to maintain security.

IMPORTANT NOTE

If your garage has no service door then an exterior release kit **MUST** be fitted. This accessory allows manual operation of the garage door from outside in case of an emergency.

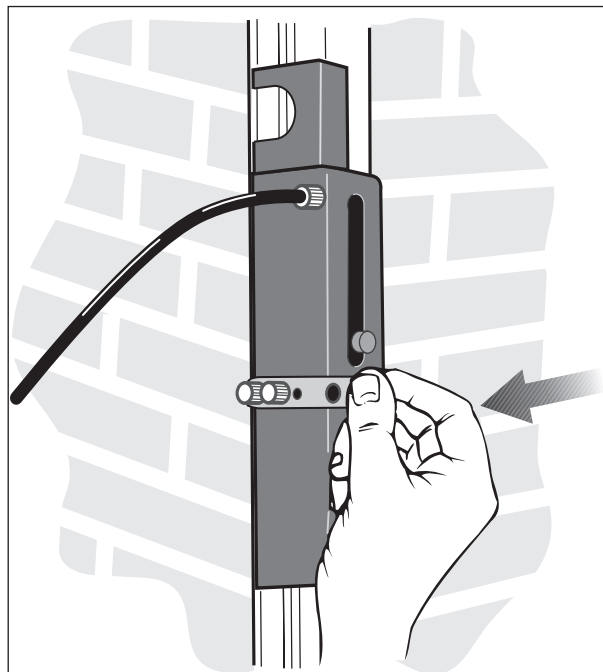

● **Figure D**

3 In the event of power cuts

- 1 If the garage door remains unused during the power cut, you have to do nothing. The control unit will automatically reset itself when the power comes back on.
- 2 If you have to use the garage door then the manual release lever can be utilised to give manual operation. See **Section 2** for details.
- 3 Turn off mains power to the control unit when in manual mode.
- 4 Re-engage motor drive when mains power is restored. See **Section 2** for details.

IMPORTANT NOTE

When using the door in manual mode you should lock/unlock the door with the key to maintain security.

4 Remote control

- 1 **Operation of handset**
 - Press the button for approx 1 second, the red LED on the handset indicates the signal is being sent.
 - The handset is not directional and does not have to be pointed at any sensors.
 - It should work perfectly from within an enclosed car, you do not have to wind down the windows.
- 2 **Handset battery**
 - The handset is powered by a 12v alkaline battery type GP23AE.
 - If the LED, on the handset begins to 'flash' when the transmit button is depressed, this indicates a LOW BATTERY condition and the battery must be changed.
(see overleaf for availability)

AUTOGLIDE

smart entry system

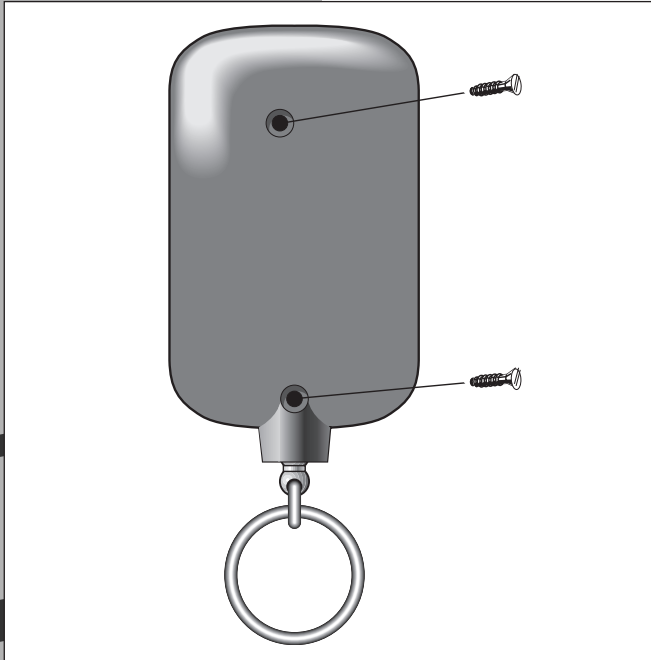

● Figure E

3 Changing battery

- Using a small Philips screwdriver carefully remove and retain the two screws from the rear of the handset (see Figure E).
- Prise apart the two halves of the handset and remove the old battery.
- Replace with new battery ensuring that it is the correct way round
- Re-assemble cover and tighten screws.

DISPOSE OF THE OLD BATTERY SAFELY AS PER MANUFACTURERS RECOMMENDATIONS

NOTE: New batteries (type GP23AE can be obtained from:–

Cardale spares department telephone:
Direct phone/fax (01280) 840471
Main switchboard (01280) 703022
Quote part No. AZSP 7036

Farnell Ltd telephone: 01132 636311
Quote part No. 724-051

CPC Ltd telephone: 01772 654455
Quote part No. BTGP 23AE

5 Safety sensitivity check

The safety reverse system should be tested once a month to ensure correct operation and to maintain safety.

Your Autoglide control system contains advanced electronics that monitor the power over the full OPEN/CLOSE cycle and computes a SENSITIVITY FACTOR to ensure user safety.

To check the operation of this, signal the door to close and when it is halfway down obstruct the door at the bottom edge using both hands.

Using only light to medium force the door should stop and then reverse to the fully open position.

If excessively heavy force (or extremely light force) is required to stop the door then RE-CONFIGURE the POWER and SENSITIVITY SET UP as instructed in **Section 6a**.

6 Configuring your Autoglide operator

Autoglide can be quickly and easily set-up by the use of three buttons, each of which has a corresponding status LED.

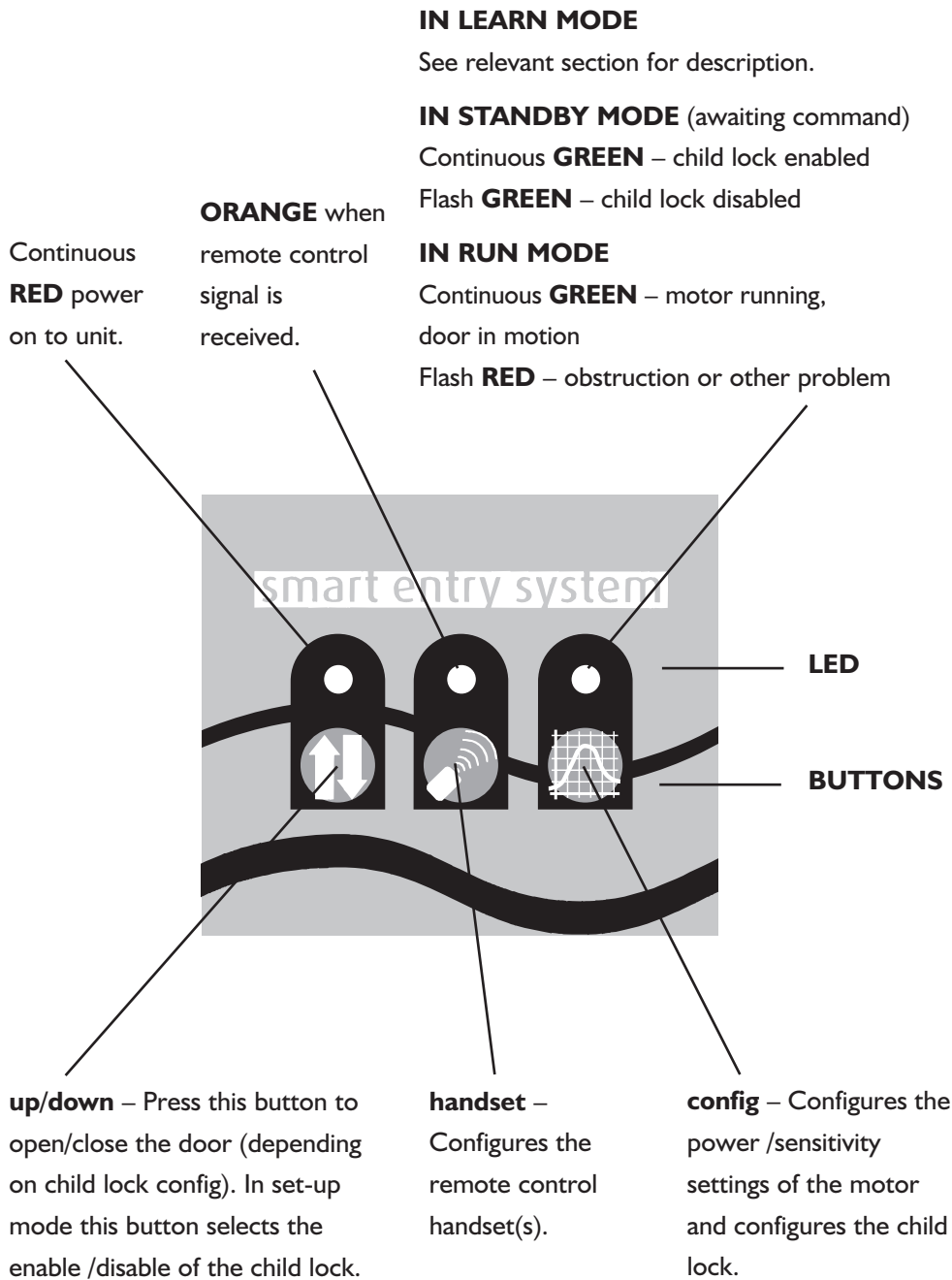

● Figure F

AUTOGLIDE

smart entry system

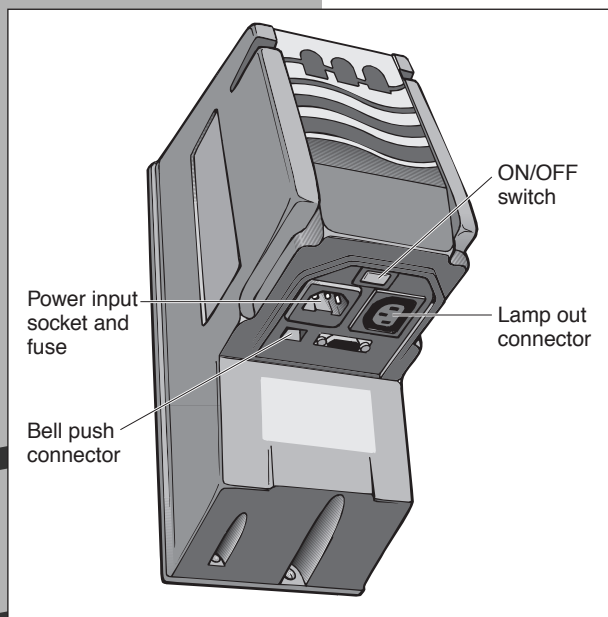

● Figure G







6a Configuring the power and sensitivity set up

Ensure that the power switch on the unit is in the **OFF** position (see **Figure G**).

NOTE: Before commencing power set up sequence ensure that:–

- a Limit switches are correctly set
- b All latches operate correctly
- c Drive pin is correctly engaged
- d Door is clear of obstructions

Check the power supply cable is plugged in (see **Figure G**) and mains is turned on, leave the switch on the unit turned **OFF** for the moment.





- 1 Press and hold down the  button.
Turn on the unit power switch then release the button.
 - 2 The **RED LED** above the button  should flash briefly to show door is between the limit switches.
Briefly press the  button once to move the door to the fully open position.
- NOTE:** If the motor runs but the door does not move and the  LED flashes red, **TURN OFF POWER**. Ensure drive pin is correctly engaged in drive tape (see Section 2) Then restart set up sequence.
- 3 With the door now fully open, briefly press the  button once to close the door for the **DOWN LEARN** sequence.
 - 4 When the door is closed briefly press the  button again to open the door for the **UP LEARN** sequence.
 - 5 The  LED should now show green or flashing green to confirm that set-up has been successfully completed.

NOTE: Where necessary, move the limit switches up or down (no more than 6mm at a time) to ensure the door fully opens and closes without excessive slamming. Go through stages 1–4 each time a limit switch is adjusted.









6b Configuring the remote control handset

Ensure that the power switch on the unit is in the **OFF** position (see **Figure G**)

Check the power supply cable is plugged in (see **Figure G**) and mains is turned on, but leave the switch on the unit turned off for the moment.

- 1** Press and hold down the  button and turn on the unit power.
- 2** Release the  button.
- 3** Briefly press the  button again
- 4** The  LED will light orange.
- 5** Press either button on the handset. The orange LED will go out.
- 6** Press either button on the handset again. The orange LED will flash for approx 10 seconds.





NOTE: To set up another handset repeat stages 5–6. When you have finished setting up the handsets(s) continue with stage 7.

- 7** Configuration of the handset buttons – with the  button released, press the handset button that you wish to use to operate the door.
The  LED should light orange to acknowledge receipt of the signal.
In addition, if the left handset button is pressed the  LED will flash red, if the right handset button is pressed the  LED will flash green.
If you want to change buttons, press both buttons simultaneously to reset. (The  LED will flash orange briefly and the LED above  will flash red then flash green) then repeat stage 7.
- 8** To configure additional handsets also repeat stage 7.
- 9** Press the  button to store your settings.
- 10** The  LED should show green/flashing green, indicating that the handset(s) have been successfully configured.

AUTOGLIDE

smart entry system











NOTES:

- A** Up to a maximum of 8 handsets can be memorised into the control unit.
- B** If you wish to ERASE handset codes:-
- Follow previous  instructions to step 2 inclusive.
 - Press  hold  button for 10 seconds and release (orange LED will flash).
 - Press  button to accept this instruction.
 - The  LED will now show GREEN/FLASHING GREEN indicating that you have returned to normal STANDBY MODE.
 - This will have erased ALL stored handset codes, if there are any that you wish to retain you must re-enter them by following previous steps 1-13.
- C** Courtesy lamp (if fitted).
- In standby mode it is possible to turn on the courtesy lamp (without operating the door) by simply pressing both buttons on the handset simultaneously.
 - The lamp will stay on for approximately 3 minutes before automatically turning itself off.

6c Configuring the child lock

Ensure that the power switch on the unit is in the off position (see **Figure G**).

Check the power supply cable is plugged in (see **Figure G**) and mains is turned on, but leave the switch on the unit turned off for the moment.

- 1** Press and hold down the  button. Turn on the unit power switch.
- 2** The  LED should briefly flash green.
- 3** Release the  button.
- 4** The  LED will now be red or green.
- 5**  LED, the lock is DISABLED i.e. door can be opened using the  button.
- 6** If  LED, then lock is ENABLED i.e. door cannot be opened using the  button.
- 7** To change the status of the lock press the  button and the  LED will

AUTOGLIDE

smart entry system

change to either red or green as the button is depressed.

- 8** To save the child lock settings press and release the button.
- 9** If the lock is disabled the LED will flash green (can open door).
- 10** If the lock is enabled the LED will shine constant green (cannot open door).

NOTE: Whether the child lock is enabled or disabled, Autoglide can still be operated using the handset.



SAFETY NOTE: If there is a chance that children may play in the entry of the garage

7 Adjusting top & bottom limits

then ensure the child lock is **ENABLED** so that the door **CANNOT** be operated from the button

Turn power switch on unit to **OFF** whilst making adjustments

NOTE: Do not strain the limit switch cables.

Temporarily withdraw the cables from the drive track grooves (if necessary) and refit correctly after adjusting limit switches.

Use a small Philips screwdriver to undo retaining screw prior to adjusting limit switch and re-tighten when adjustment is completed.

Adjusting bottom limit switch (see Figure H)

- If door **fails to close** then move switch **downwards**.
- If door **slams too heavily** or **slams and**

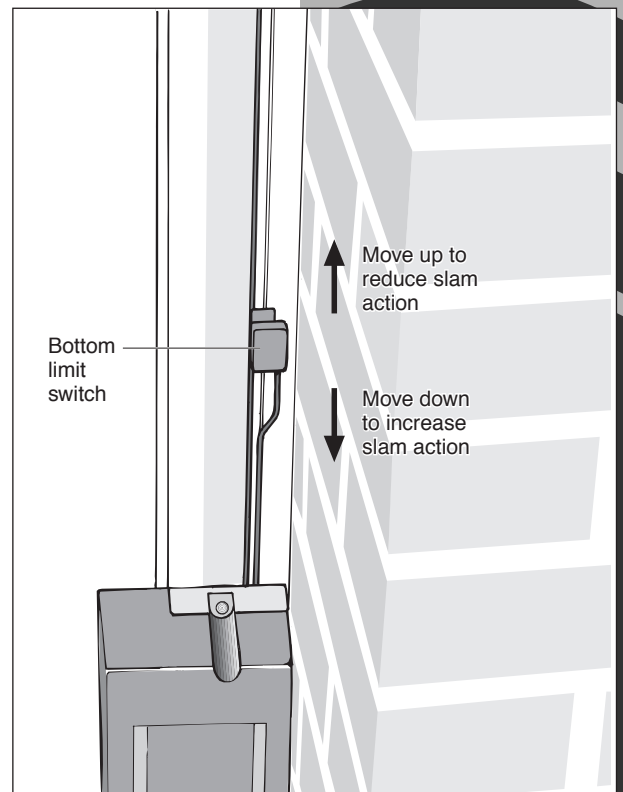

● Figure H

AUTOGLIDE

smart entry system

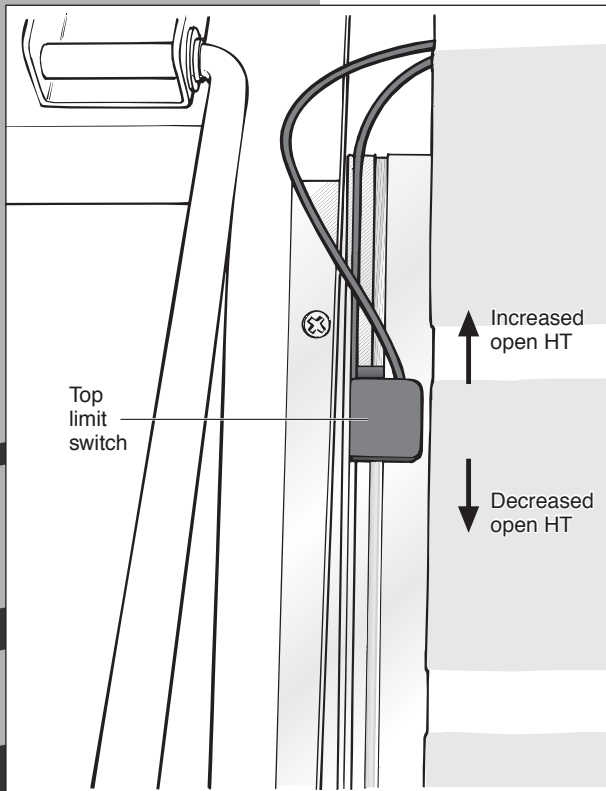

● Figure J

8 Check/adjust latch setting

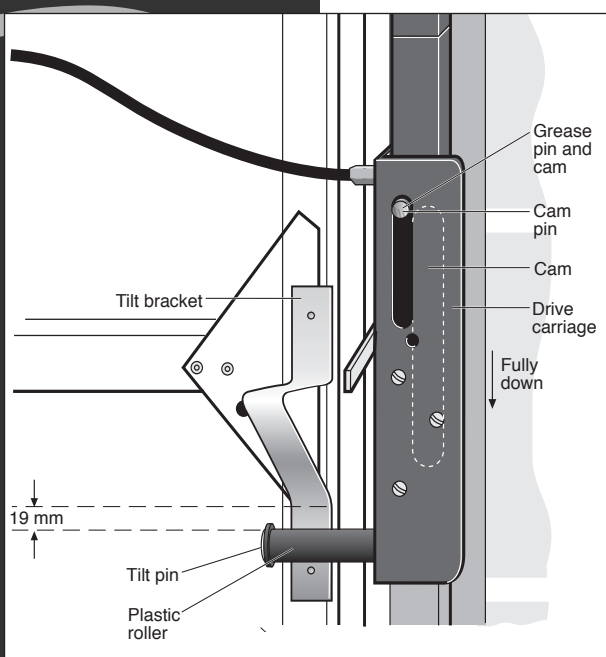

● Figure K

opens again immediately then move switch upwards.

2 Adjusting top, limit switch (see Figure J)

- If door **fails to open far enough** then move switch **upwards**
- If door is **opening too far** and hitting track stops or straining lifting gear then move switch downwards.

NOTE: Only move the limit switch 1–2mm at a time and test door operation by switching power back on and opening/closing door.

IMPORTANT: Reconfigure the power and Sensitivity settings after adjusting the limit switches (see Section 6a).

Operate door from inside garage and observe movement of latches to ensure full disengagement before door starts to open. If latch pins are failing to disengage proceed as follows:–

1 Check that drive carriage is in the fully down position (see Figure K) when door is fully closed.

2 Check that latch pins are adjusted for correct engagement (see Figure L). If adjustment is required:–

- For coarse adjustment undo cable clamp and adjust cable length (Figure L).
- For fine adjustment use cable adjuster (see Figure M).

3 Apply small amount of grease to latch cam and pin (see Figure K) and also to latch pins and plates on the door to ensure smooth operation.

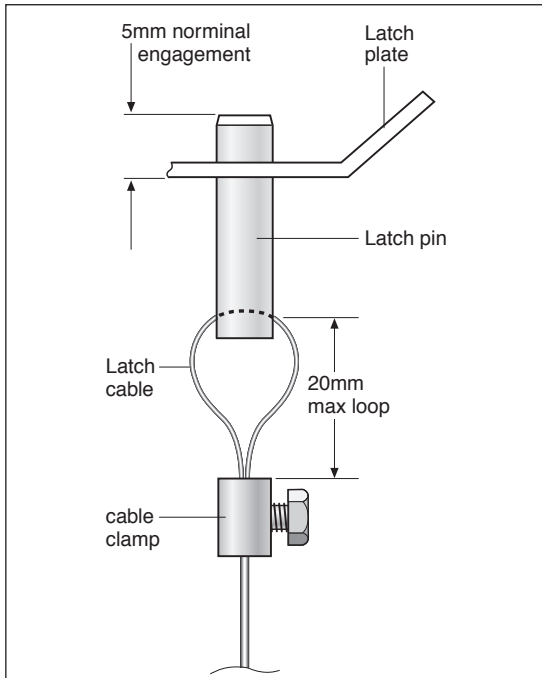

● Figure L

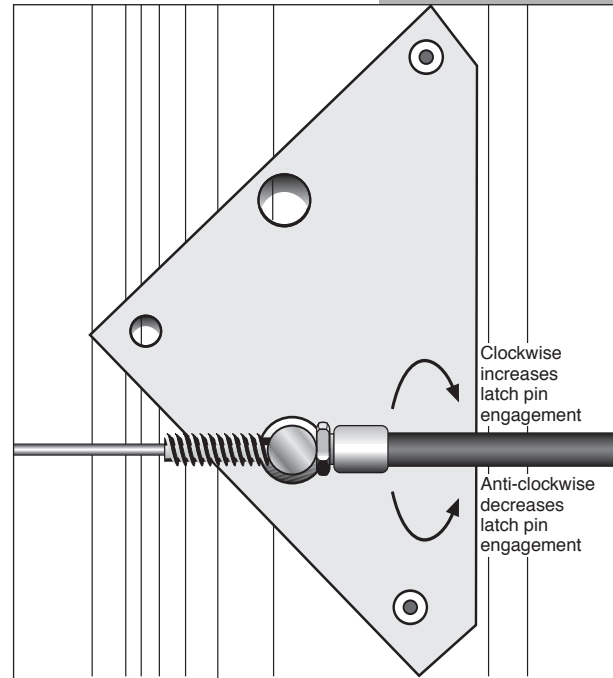

● Figure M

9 Maintenance

1 Door panel/Springs

- It is important that the door and spring system is kept regularly maintained and lubricated– see maintenance label on the back of the door.
- Frequently examine the installation, in particular the cables, spring and mountings, for signs of wear, damage or imbalance. Do not use if repair or adjustment is needed since a fault in the installation or an incorrectly balanced door may cause injury. Call for professional garage door service.

2 Control system

Contains no user serviceable or adjustable parts therefore the control cover **SHOULD NOT** be removed.

3 Drive system



- Check for smooth operation of latch release cam and occasionally grease the cam and pin. (see **Figure K**) together with latch pins and plates on the door.
- Once a month test the Safety Reverse System. (see **Section 5**)

10 Problem solving

1 UNIT FAILS TO OPERATE WHEN MAINS POWER SWITCHED ON.

- a. If red LED above  is **NOT LIT**:-
- Remove power lead 13A plug from supply socket.
 - Use test lamp to check power is available at the 13A socket.
 - Check fuse in 13A plug (NB should be fitted with a 5A Fuse.)
 - Remove power lead from the Autoglide unit.
 - Check fuse in the Autoglide power input socket (see **Figure G**)

N.B. Should be fitted with a 250v 2A slow blow x 20mm long fuse.

- b. If Red LED above  is **LIT**:-
- Check if unit can be operated from either :-
 - i The remote handset
 - ii The  button on the control unit (provided child lock is disabled, shown by a flashing green LED)
 - iii The remote bell push button

If *any* of these operate the door then the unit is functioning properly.

The 'start' methods that failed to operate the door will need to be checked out separately, see in later sections.

- Should the unit fail to operate by any of the above "start" methods:-

- i Turn the power switch on the unit to the OFF position.
(see **Figure G**)
- ii Wait for 5 seconds then turn back ON again. This will re-set the control system.
- iii Re-try "start" methods as above.

2 MOTOR OPERATES BRIEFLY BUT DOOR REMAINS FULLY CLOSED.

(the  LED flashes briefly RED)

- Door not de-latching correctly
- Check adjustment/operation of latches (**Section 8**)

3 MOTOR OPERATES BUT DOOR DOES NOT MOVE (MOTOR RUNS ON)

(the  LED flashes intermittent RED)

- Motor drive not engaged
- Check drive pin correctly engaged (**Section 2**)

4 MOTOR OPERATES BUT DOOR FAILS TO FULLY OPEN OR CLOSE

(the  LED flashes briefly RED)

- i. Turn OFF mains power to unit and read safety notes at the front of this manual.
- ii. Operate manual release lever to disengage drive (**Section 2**).
- iii. Test door operation and correct any binding or out of balance.
- iv. Re-engage drive (**Section 2**) and turn power back on.
-Reconfigure power and sensitivity settings (**See section 6a**)

5 DOOR CLOSSES BUT LATCHES DO NOT ENGAGE

- Check latch cable settings (**Section 8**)
- Grease latch release cam and pin on drive carriage. (see **Figure K**)
- Grease latch plates and latch pins on door.
- Check bottom limit switch has been set low enough to ensure 'slam action' of latches. (**Section 7**)

6 DOOR SHUTS TOO VIOLENTLY OR SHUTS AND THEN OPENS AGAIN IMMEDIATELY.

- Adjust the bottom limit switch to a slightly higher position. (**Section 7**)

7 UNIT FAILS TO OPERATE AND LED FLASHES ALTERNATE RED/GREEN.

- Indicates a limit switch fault:-
 - i Switch off power to unit and read safety notes at front of this manual.
 - ii Operate manual release lever to disengage drive (**Section 2**) and manually move door to half open position.
 - iii Check operation of both limit switches by depressing the small plunger pin several times to ensure that it springs back out again, and that there is an audible 'click' from the switch.
 - iv RE-engage drive (**Section 2**) and turn power back on.
 - v Test operation again.

If LED still flashes alternate RED/GREEN then a limit switch is damaged/faulty and will require a service engineer visit.

AUTOGLIDE

smart entry system

8 UNIT FAILS TO OPERATE FROM REMOTE BELL PUSH.

- Check connections to bell push are correct and secure.
- Check operation of bell push button “makes/breaks” the contacts.
- Check wiring for damage/breaks and is routed away from any mains electrical cables.
- Check connections to 2 way plug in Autoglide unit are correct and secure. (see **Figure G**)
- Check 2 way plug is fully engaged into socket in Autoglide unit.



9 UNIT FAILS TO OPERATE FROM REMOTE CONTROL HANDSET

- Check that signal is being sent from the handset. (see **Section 4**).
- Check that Autoglide unit is receiving the signal. The  orange LED should light up when the handset is pressed to indicate that signal is being received.

if this fails to happen:–

- Check that handset has been configured into the control system (see **Section 6b**).
- Check that correct handset button has been pressed (try other button to make sure)
- Check handset signal (see above).

10 UNIT FAILS TO OPERATE FROM BUTTON.

- Check that the unit has been configured to operate  button. (flashing  green LED)

To change configuration refer to **Section 6c** paying particular attention to the **SAFETY NOTE**.

AUTOGLIDE

smart entry system

The following accessories are available for use with your Autoglide MK III operator

AZAA 3152	Additional handset (433 Mk III-A)
AZAA 3120	Exterior release kit (Cardale CD45)
AZAA 3141	Lamp kit
AZAA 3160	Electric key switch
AZAA 3101	Retro fit kit for Henderson Premier (cable latch)
AZAA 3102	Retro fit kit for Garador Mk III 'C'
AZAA 3103	Retro fit kit for Henderson Premier (solid bar)
AZAA 3104	Retro fit kit for Henderson Pre-premier doors (after 1987)
AZAA 3121	Exterior Release kit for Henderson Premier (cable latch)
AZAA 3122	Exterior Release kit for Garador Mk C 'C'
AZAA 3123	Exterior Release kit for Henderson Premier (solid bar)
AZAA 3124	Exterior Release kit for Henderson Pre-premier (after 1987)
AZSP 7036	Replacement handset battery

Technical information

Power supply

- 230v ac 50Hz (supplied with 13A 3 pin plug fitted with 5A fuse)

Power requirement (Drive unit only)

- Standby mode 8w
- Run mode 60w (Excluding lamps)

Max pull/push force

- 400N

Lamp unit(s)

- Up to Max 120w total (suitable for 230v ac 50Hz supply)
- Lamp automatically switches off after approx 3 minutes
- Must be INCANDESCENT lamps. DO NOT fit fluorescent or halogen lamps

Internal fuse

- Fitted in power input socket (250v 2A slow blow x 20mm long)

Motor transformer and control

- Built in transformer
- Low voltage ca 24 volt D.C. geared motor
- Micro processor control "smart entry system" auto calibrating

Areas of use

- For use inside the garage only
- Only use on Cardale CD45 doors and CD PRO Doors.
- Max door size 8'0" wide x 7'0 high (2438 x 2134)

NOTE: Conversion kits are available for other manufacturers gear systems

AUTOGLIDE

smart entry system

Warranty information

Your Autoglide garage door operator is guaranteed for 2 years from date of installation.

Should you have a problem with this product that you can not overcome by following the "Problem Solving" guide then please consult your installer or Cardale warranty department.

Please quote the information shown below and the **WKS O/N** reference number from the label below.

Date installed _____ Installed by _____

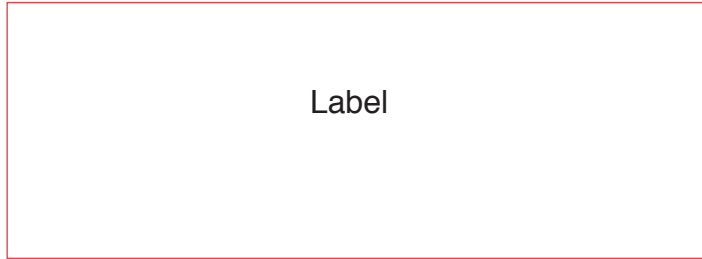

To ensure this Autoglide unit provides optimum performance, it is strongly recommended that this unit is serviced on an annual basis by a qualified Cardale Dealer.

	DATE	SERVICED BY
Service No.1	_____	_____
Service No.2	_____	_____
Service No.3	_____	_____
Service No.4	_____	_____
Service No.5	_____	_____

Supplied and serviced by:

IMPORTANT: This document contains warranty information that is unique to this unit. Please ensure that it is passed on to the homeowner.

CARDALE SERVICE HOTLINE 01280 705077